



www.reevegroup.com.au

PUMPS & IRRIGATORS

VERTICAL CANTILEVER PUMP

**BUILT TO HANDLE EFFLUENT & SOLIDS
NO SEALS OR BEARINGS IN WETTED AREAS**

AUSTRALIAN MADE



OVER 40 YEARS OF PUMPING EXPERIENCE GIVES YOU...



PERFORMANCE TO MEET YOUR NEEDS

Wide selection of single and 3-phase electric motor drives 2.2kW (3hp) up to 11kW (15hp) delivering high heads and discharge for fast effluent disposal and for operating travelling irrigators.

VEE BELT DRIVEN FLEXIBILITY

For easy pump speed selection to match discharge head and pumping capacity to suit your requirements.

HEAVY DUTY, LUBRICATED BALL BEARINGS ABOVE LIQUID LEVEL

Long lasting wear capabilities.
Tolerates long-term heavy workloads.

LARGE DIAMETER HIGH TENSILE RIGID SHAFT

Smoother, more efficient running
Longer bearing life

NO BEARINGS, SEALS OR SLEEVES BELOW LIQUID LEVEL

Longer pump life, no metal-to-metal wear
Can run dry indefinitely without damage, saving on costly pump maintenance and repairs.

PATENTED NON-CLOG "CHOPPER" IMPELLER

Far less downtime potential
Chops up semi-solids, straw, grass etc.
Allows sand, gravel and small stones to pass.

BOTTOM SUCTION INLET

For cleaner pits with minimum residue. Easy, inexpensive extension pipe fitment for deeper pits.
Standard Inlet: 2-1/2" BSP Optional: 3" BSP

OUTLET

A 2" BSP discharge pot is fitted with galvanized steel bend for easy connection of your discharge pipe.

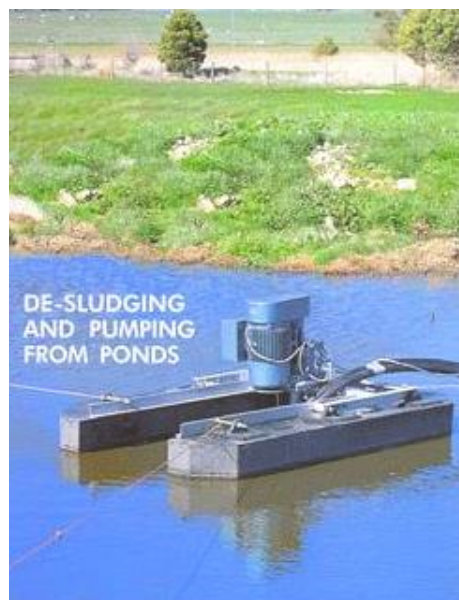

ONLY REEVE EFFLUENT PUMPS OFFER YOU ALL THESE ADDITIONAL BENEFITS...

EFFICIENT DESIGN gives higher head capacity for pumping uphill, long distances, or spraying with lower power costs.

SWING UP MOUNTING BRACKETS included for easy installation.

FULL 860mm (34") PUMP REACH, with bottom inlet for full depth suction and easy fitting of extension inlet pipe.

TWIN VEE BELT DRIVE, STRONG CAST IRON PULLEY for longer life and positive drive with flexibility of pulley change for easy performance selection.

PRECISION GROUND SHAFTS at bearing locations for secure mounting and extra-long service life.

HEAVY DUTY CAST IRON PUMP COMPONENTS for long lasting wear against abrasive materials

FREE TURNING IMPELLERS - no underwater bearings or supports, ensuring long life even while running dry or pumping abrasive liquids

LESS WORKING PARTS for simple maintenance and highly efficient operation

12 MONTH WARRANTY to show our commitment and confidence in your investment.

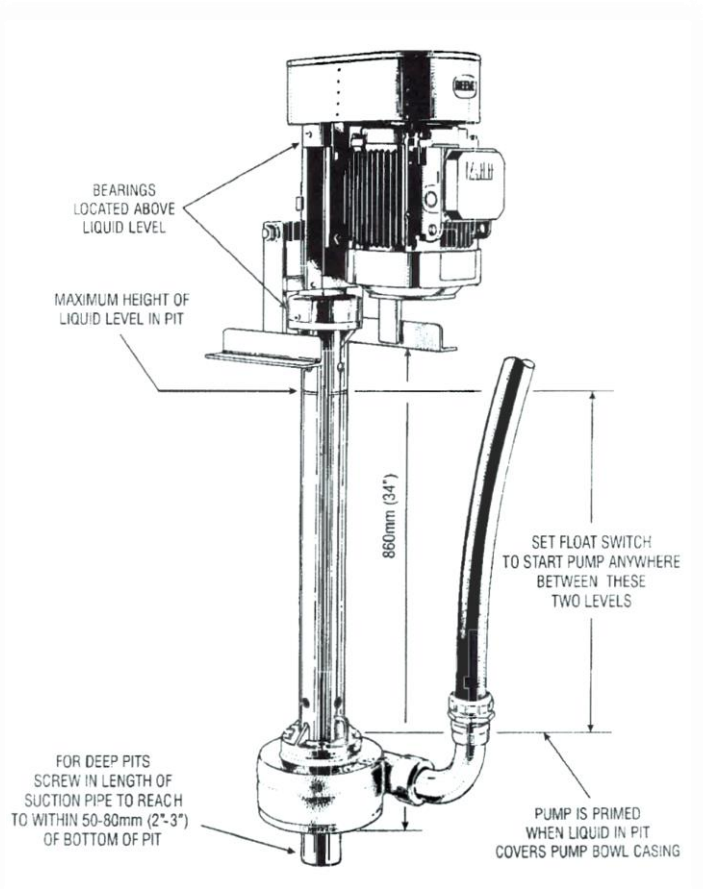

OPTIONS



"SUPER 10" INVERTED MOTOR MOUNT

Raises the motor high above the water level.

Acts as a counter balance to help swing the pump up for maintenance.

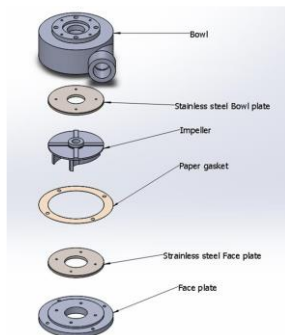

HARD WEAR KITS

For abrasive applications, a hard wear kit provides a hard wearing stainless steel impeller and replaceable stainless steel wear plates for improved wear resistance.



STAINLESS STEEL OPTIONS

For corrosive environments and fluids, most components are available in 316 stainless steel. Bowl, face plate, impeller, shaft and support tube.

PERFORMANCE CURVES

